

GENERAL SERVICE PUMPS

A-SERIES PUMP DIMENSIONS

SERIES A2-A8

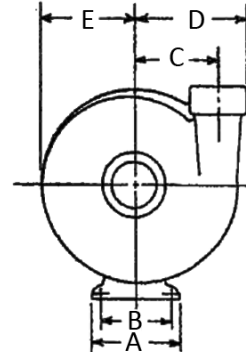
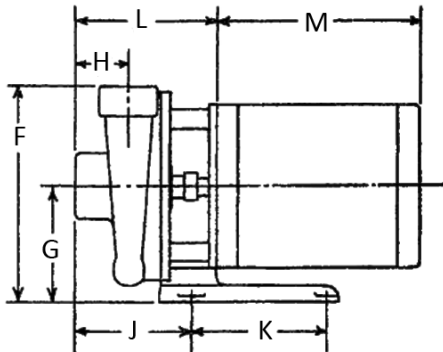

Pump Series	Discharge (NPT)	Suction (NPT)
A2-A3	1" NPT	1 1/4" NPT
A4-A6	1 1/4" NPT	1 1/2" NPT
A7-A8	1 1/2" NPT	2" NPT

SERIES A9-A10

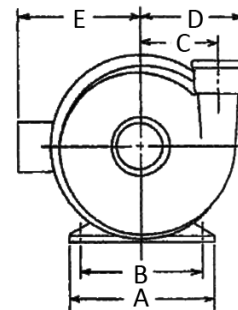
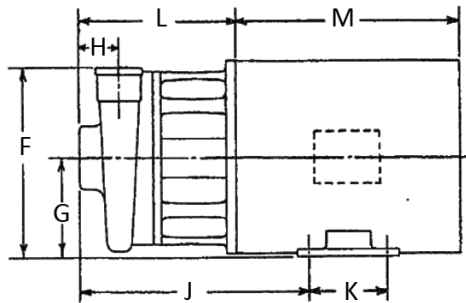

Pump Series	Discharge (NPT)	Suction (NPT)
A9	1 1/2" NPT	2" NPT
A10	1 1/2" NPT	2" NPT

DIMENSIONS IN INCHES

Series	A	B	C	D	E	F	G	H	J	K	L	M	FR
A2	4 7/8	3 3/8	3 3/8	4 1/2	3 3/8	8 3/4	4 3/4	2 1/4	4 3/8	5 7/8	5 7/8	8 3/16	56C
A3	4 7/8	3 3/8	3 3/8	4 1/2	3 3/8	8 3/4	4 3/4	2 1/4	4 3/8	5 7/8	5 7/8	8 9/16	56C
A4	4 7/8	3 3/8	3 3/8	4 1/2	3 3/8	8 3/4	4 3/4	2 1/4	4 3/8	5 7/8	5 7/8	9 3/16	56C
A5	4 7/8	3 3/8	3 3/8	4 1/2	3 3/8	8 3/4	4 3/4	2 1/4	4 3/8	5 7/8	5 7/8	10	56C
A6	4 7/8	3 3/8	3 3/8	4 1/2	3 3/8	8 3/4	4 3/4	2 1/4	4 13/16	5 7/8	5 7/8	11	56C
A7	4 7/8	3 3/8	3 3/8	5 1/8	4 1/8	9	4 3/4	2 1/4	4 13/16	5 7/8	6 1/16	11	56C
A8	4 7/8	3 3/8	3 3/8	5 1/8	4 1/8	9	4 3/4	2 1/4	11 15/16	5 7/8	6 1/16	12	56C
A9	8 11/16	7 1/2	3 13/16	5 1/8	7	9 3/16	4 15/16	2 1/4	11 15/16	4 1/2	8 7/16	11.7	182TC
A10	8 11/16	7 1/2	3 13/16	5 1/8	7	9 3/16	4 15/16	2 1/4	11 15/16	4 1/2	8 7/16	12.7	184TC

Dimensions subject to change

SPECIFY WITH CONFIDENCE, SPECIFY PENN PUMP SYSTEMS

GENERAL SERVICE PUMPS

D-SERIES PUMP DIMENSIONS

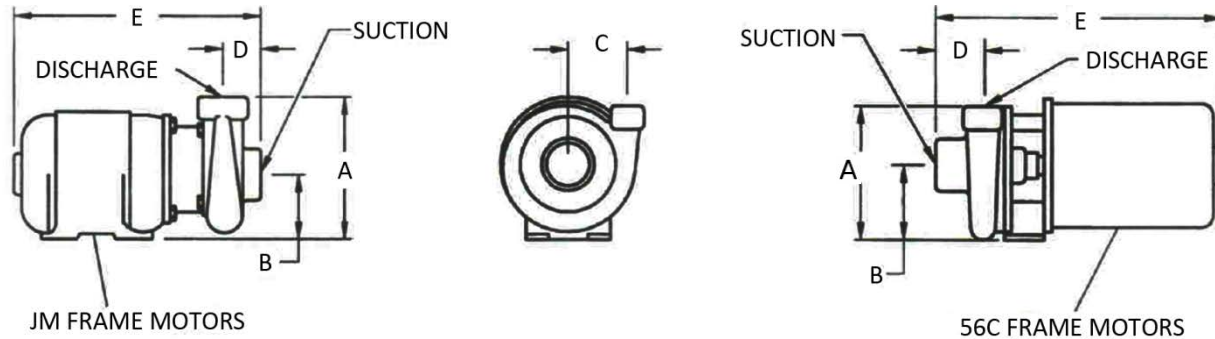

56C FRAME MOTORS

Pump Series	Discharge (NPT)	Suction (NPT)	A	B	C	D	E 56C Frame Motor HP			
							1	1 ½	2	3
D25-D50	1	1 ½	9	5	3 ¾	2 ¼	-	-	16 ½	17
D60-D90	1 ½	2	9 ½	5	4	2 ½	15 ¾	15 ¾	16 ½	17
D80-D200	2	3	9 ¾	5	4 ¼	3 ¾	-	17 ¼	18	18 ½

Dimensions in inches

Dimensions subject to change

JM FRAME MOTORS

Pump Series	Discharge (NPT)	Suction (NPT)	A	B	C	D	E JM Frame Motor HP								
							5	7 ½	10	15	20	25	30	40	50
D50	1	1 ½	9	5	3 ¾	2 ¼	18	-	-	-	-	-	-	-	
D90	1 ½	2	9 ½	5	4	2 ½	18 ¼	19 ½	-	-	-	-	-	-	
D145	1 ½	2	9, 11	3 ½, 5 ¼	5 ¾	2 ½	18 ¼	19 ½	19 ½	21	-	-	-	-	
D200	2	3	9 ¾	5	4 ¼	3 ¾	19 ¾	21	21	-	-	-	-	-	
D200	2	3	9 ¾, 12 ½	3 ½, 6 ¼	4 ¾	3 ¾	-	-	-	22 ½	26	-	-	-	
D400	3	4	11 ¾, 13 ¾	4 ½, 6 ¼	4 ¾	3 ½	20 ¼	21 ½	21 ½	23	26 ½	-	-	-	
D550	4	4	16 ½	7 ¾	6 29/64	4 23/32	-	-	-	-	28 21/32	28 21/32	29 17/32	30	

Dimensions in inches

Dimensions subject to change

SPECIFY WITH CONFIDENCE, SPECIFY PENN PUMP SYSTEMS